

ST.-BY.-PUMP AND COMPRESSOR CONTROL SERIES AHD 408



AHD 408 E

- Microprocessor-controlled device for control desk mounting.
- Controls two independent pairs of electrical pumps.
- Selector switch for main- and st.-by-pumps is installed at the front-side.
- After switching on, the st.-by-pump builds up the pressure, then the system switches over to the main pump.
- In case of a pressure drop, the st.-by-pump starts automatically; this causes an alarm.
- In case of a blackout, all pumps are stopped. After restoration of power, they only start after a pre-programmed time.
- Pressure and condition of the pumps, as well as blackout and st.-by-alarm are indicated.
- Text field can be exchanged easily.

AHD 408 A

- Microprocessor-controlled device for control desk mounting.
- Mainly used for lubrication and gear oil, where the main pumps are driven directly by the diesel engine.
- Controls the st.-by-pumps depending on the oil pressure and the speed of the diesel engine.
- St.-by-pumps are switched on at low speed of the engine (normal), as well as at high speed of the engine and falling pressure (not normal, st.-by-alarm).
- Text field can be exchanged easily.



AHD 408 E-K

- Microprocessor-controlled device for control desk mounting.
- Upper half of device is for one pair of st.-by-pumps (compare AHD 408E)
- Lower half is for one pair of compressors and operates as follows:
 - Switches main- and st.-by-compressor depending on on the air pressure.
 - If the running time of the main- and st.-by compressor exceeds the pre-programmed time, a st.-by-alarm is released.
- A selector switch for main- and st.-by-compressor is installed at the front-side.
- In case of a blackout, both compressors are stopped. After restoration of power, they only start after a pre-programmed time.
- Text field can be exchanged easily.



All devices approved by GL

St.-by-Pump- and Compressor Control Series AHD 408

Contents

	Page
1. General information about all types of devices	3
2. AHD 408E, st.-by-pump control for 2 electrical pairs of pumps	3
2.1 Function	3
2.2 Remote control of the pumps	4
2.3 System failure	4
Terminal diagram	5
Programming	5
Technical data	5
Text field	5
St.-by-pump-control AHD 408E with remote control	6
Dimensional drawing	13
3. AHD 408A, st.-by-pump control for attached main pumps	7
3.1 Function	7
Terminal diagram	8
Programming	8
Technical data	8
Text field	8
Dimensional drawing	13
4. AHD 408AE, as AHD 408 A, but with addressing of a prelubrication pump and switching-off of unimportant consumers	9
4.1 Function	9
Terminal diagram	10
Programming	10
Technical data	10
Text field	10
Dimensional drawing	13
5. AHD 408E-K, st.-by-pump- and compressor control	11
5.1 Function	11
Terminal diagram	12
Programming	12
Technical data	12
Text field	12
Dimensional drawing	13
Collective report for the alarm system	14
Text fields for labeling and cutting out	15

Description

1. General remarks for all types of devices

AHD 408-systems are microprocessor-controlled devices for control desk mounting. They are plug-in units which consist of two electronic cards in a sandwich-construction and the front panel. It is accommodated in a housing according to DIN 43700. The front dimensions are 72 mm x 144 mm and the installation depth is 216 mm.

All in- and outputs are led to a 24-pole terminal block, which is located on the rear side of the housing. The inputs are separated from the rest of the electronics by optocouplers. There are floating relay contacts available for switching on of the pump- and/or compressor-contactors. The contact configuration is done in a way that in case of auxiliary energy failure or disturbed electronic a useful condition is adjusted.

The housings are equal for all types of devices. To avoid damages, which might result of unintentional changing of the plug-in units of different devices, the terminals are assigned adequately. A plug-in unit type AHD 408E in a housing of e. g. AHD 408A does not function, but is neither damaged.

The text field in the front panel can be inserted from above. For this purpose, the plug-in unit has to be torn out a little. To protect the text field, an additional plastic foil is fixed above it.

The devices can be delivered with a normal front frame or, to increase the degree of protection, with a front-cap.

2. AHD 408E, st.-by-pump-control for 2 independently operating pairs of electrical pumps

2.1 Function

For each pair of st.-by-pumps, two keys are installed at the front panel. With the selector switch „Main Pump“, the user can determine, which of the two pumps (1 or 2) shall be the main pump. Thus, the other pump is defined as st.-by-pump. The pump pairs are commissioned with the corresponding switches „ON“.

After switching on, the computer system first checks, if there is enough pressure. As this won't be the case very often, the st.-by-pump starts first to develop the pressure. Subsequently, the st.-by-pump stops and the main pump starts. The time in between is programmable (t4). Thus, it is guaranteed that the st.-by-pump really operates and is available in case of need. If the st.-by-pump does not succeed to develop pressure, after a programmable time (t1) a st.-by-alarm is released.

If there is a pressure drop during operation, the main pump stops and the st.-by-pump starts after elapsing of time (t4). Simultaneously, the st.-by-alarm is released, which is, in detail, as follows:

- red LED ST.-BY.-ALARM flashes in the front panel
- transistor output with same definition for remote indicator switches through
- collective alarm relay output opens
- collective alarm repetition output closes for app. 3s and then opens again

In case of a power failure of the pumps during operation (blackout), the relays of the st.-by-pump-control switch into a position which at first avoids the start-up of the pumps after restoration of power. Only after elapsing of a programmable time (t_3) the pumps are connected. Thus, an overload of the board power system is avoided. For development of pressure the time t_1 is available again.

In case of power failure of the electronics or breakdown of the device, all relays switch into resting position. If the pump-control is activated, the main pumps switch. Most likely, they were already in operation before.

Furthermore, switch-over of the operating pump with the selector switch is possible. Thus, manual operation is possible even in case of breakdown of the electronics. As the collective alarm relay also drops in this case, a transmission to a usually available alarm system is done.

Besides the mentioned function, the „ON“-switches have also a reset-function. By switching off and then on again, an active st.-by-alarm is reset.

2.2 Remote control of the pumps

The previously described function refers to local operation, e.g. the pump control is located near the pumps or in the engine control room. If a remote control, e. g. on the bridge, is required, an additional binary data station PS 47-1-08 is necessary (compare page 5 of this description).

Here, the switches with the function „Remote control - Stop - Local control“ (S3) and the selector switches with „stop-function“ (S1, S2) are connected. The data station transforms the switch positions into a serial output signal and transmits them over just one wire to the st.-by-pump-control.

If the switch S3 is in „Local Control“-position, the remote control is switched off and AHD 408E is operated directly at the device. In this case, S1 and S2 have no function. If the switch is in „Remote Control“-position, the functions for S1 and S2 are activated, i.e. they are selector switches to determine which pumps shall work as main- or st.-by-pumps. Also, the pumps can be switched off from here.

2.3 System failure

In case of a failure of the st.-by-pump-control, the red LED indicates „System Fault“ at the front panel by a permanent light. Furthermore, the collective alarm relay drops. If the binary data station PS 47-1-08 does not transmit any data or if the switches S1, S2 or S3 are not connected correctly, the LED „System Fault“ flashes. The collective alarm relay drops, too. The relay with the function collective alarm repetition responds for a few seconds and then drops again.

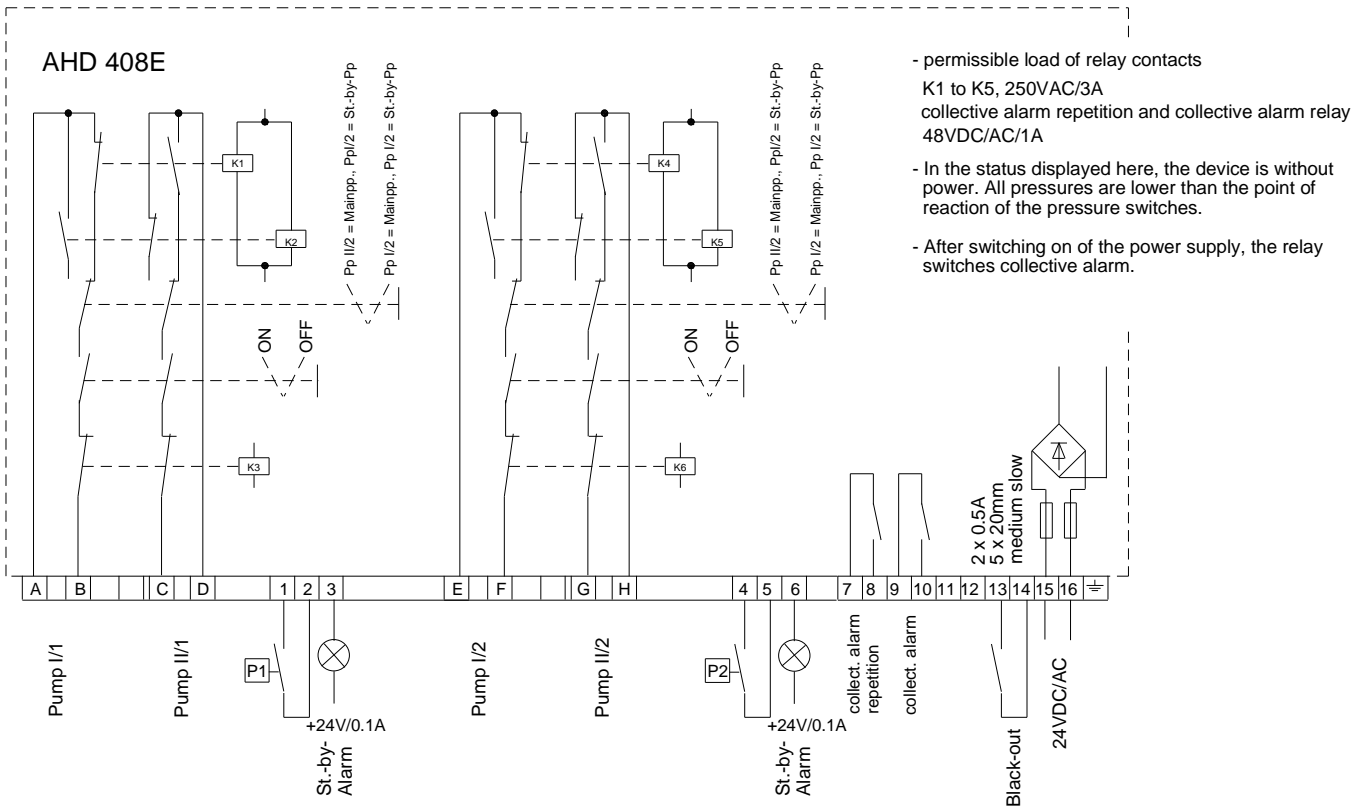

The EEPROM (Type 28C64) is located on the upper card of the plug-in unit. If it has to be reprogrammed, the plug-in unit has to be torn out after loosening the screw in the front panel.

Upper part of device	EEPROM address	Content (min)	EEPROM address	Content (sec)	EEPROM address	Content ⁽¹⁾ (NC/NO)
t1	1700		1701		----	----
t2	----	----	1702		----	----
t3	----	----	1703		----	----
t4	----	----	1705		----	----
Press. switch	----	----	----	----	1704	

1) Pressure at closed contact Content of address = 01
 Pressure at opened contact Content of address = 00

- t1) Permitted time from switching on the st.-by-pump until reaching operating pressure during the start program. This time is identical with the time that is available for the operating pump after a black-out to redevelop the pressure (0-99min and 59s).
- t2) Time between pressure drop and stopping of the main pump (0-99s)
- t3) Time until restarting of the operating pump after a black-out (0-99s).
- t4) Time from stopping of the st.-by-pump until starting of the main pump during the start program and at st.-by-alarm from main pump off until st.-by-pump on.

Lower part of device	EEPROM address	Content (min)	EEPROM address	Content (sec)	EEPROM address	Content ⁽¹⁾ (NC/NO)
t1	1710		1711		----	----
t2	----	----	1712		----	----
t3	----	----	1713		----	----
t4	----	----	1715		----	----
Press. switch	----	----	----	----	1714	

TECHNICAL DATA

- Power supply : 24VDC/AC
- Consumption of the electronics : app. 0.3A
- Degree of protection : - Front : - IP 20 (with front-cap IP 54)
- Rear : - IP 00
- Installation depth : 216mm
- Panel cutout : 138mm x 67mm
- Weight : app. 1kg

Marking of the pump circuit

Marking of the pump circuit

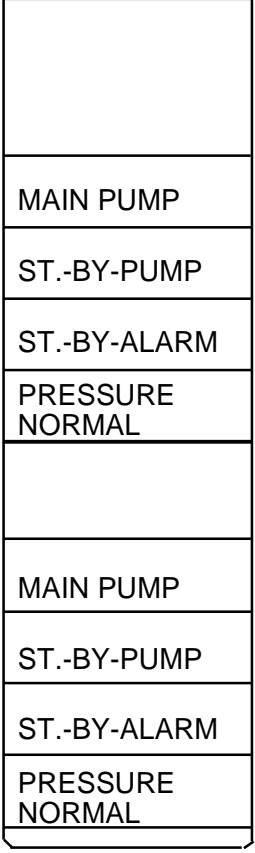

Text field for marking, cutting out and insertion from top into the front panel.

St.-By Pump Control AHD 408E with Remote Control

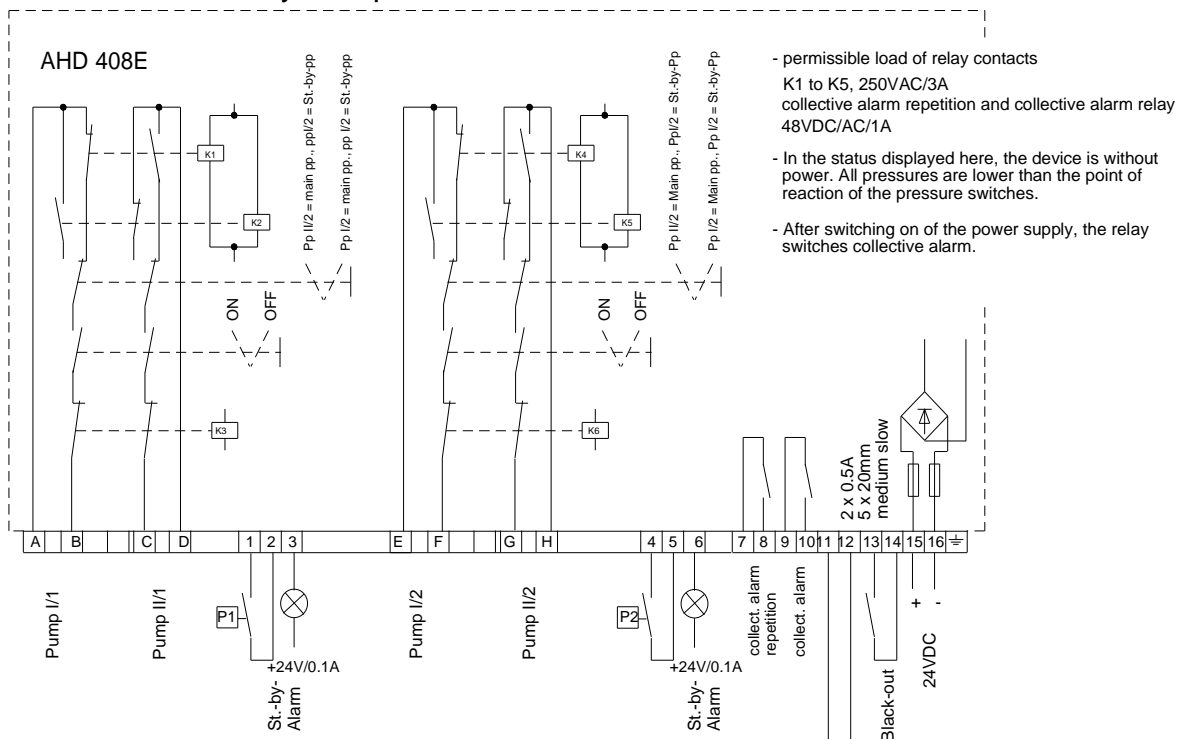

- permissible load of relay contacts
K1 to K5, 250VAC/3A
collective alarm repetition and collective alarm relay
48VDC/AC/1A
- In the status displayed here, the device is without power. All pressures are lower than the point of reaction of the pressure switches.
- After switching on of the power supply, the relay switches collective alarm.

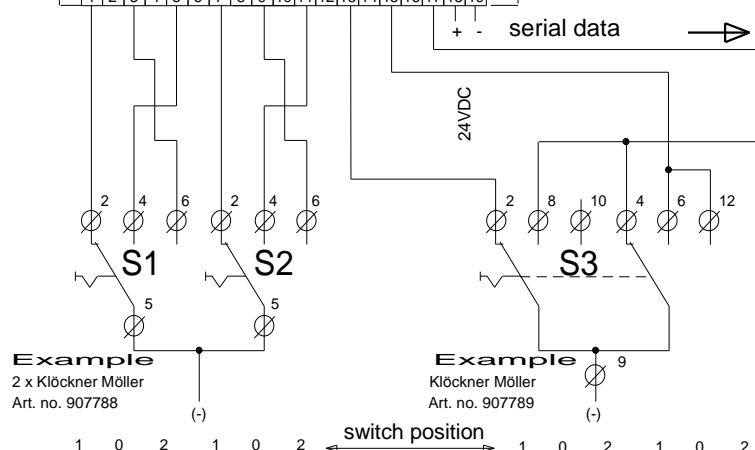
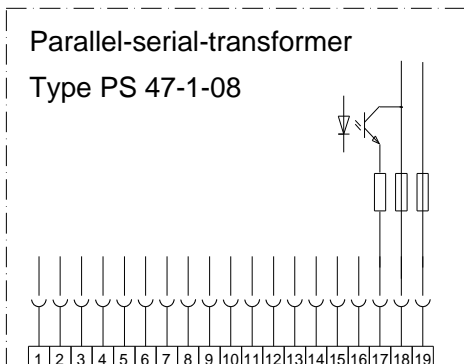

- Pos 1: Pump I = main pump, pump II = st.-by-pump
- Pos 0: Pump I and II stop
- Pos 2: Pump II = main pump, pump I = st.-by-pump

- Pos 1: Remote control
- Pos 0: All pumps stop
- Pos 2: Local control

Dimensional drawing PS 47-1-08

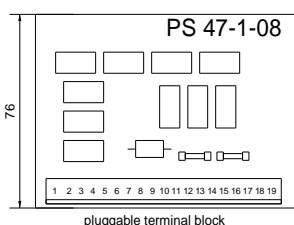
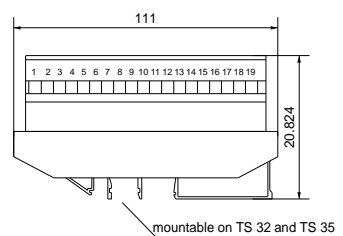

3. AHD 408A, St.-by-pump-control for attached main pumps

3.1 Function

AHD 408A contains two controls for each st.-by-pump, which work independently of each other. The main pumps are driven by the ship's main engine.

The following three states have to be distinguished:

- If the st.-by-pump-control is switched off, the relay to address the auxiliary contactor has dropped (contact open). Pressure- and speed-switch have no influence.
- If the st.-by-pump-control is switched on and the engine is in resting position or operating at low speed, the st.-by-pump is switched on. This state is normal, so no st.-by-alarm is released. If the speed rises until the speed switching unit reacts, the st.-by-pump stops after a programmable time (t2).
- If now the pressure drops at a high speed, the st.-by-pump starts again after the programmable time t1. Simultaneously, a st.-by-alarm is released, which is in detail as follows:
 - red LED ST.-BY.-ALARM lights up at the front panel
 - transistor output with same definition for remote indicator switches through
 - collective alarm relay output opens
 - collective alarm repetition output closes for app. 3s and then opens again

In case of a tachogenerator failure, it is possible that the electric st.-by-pump is running, too, despite a high speed and sufficient pressure that is generated by the attached main pump. In order to avoid this, the control has an input Fr, which, if it is activated, monitors the speed sensor n1. If the input Fr is activated and there's no signal from the speed sensor n1, there will be an alarm. This means that the LED „Speed high“ flashes and the collective alarm relay drops. The collective alarm repetition relay closes for appr. 3s and then opens again.

AHD 408A

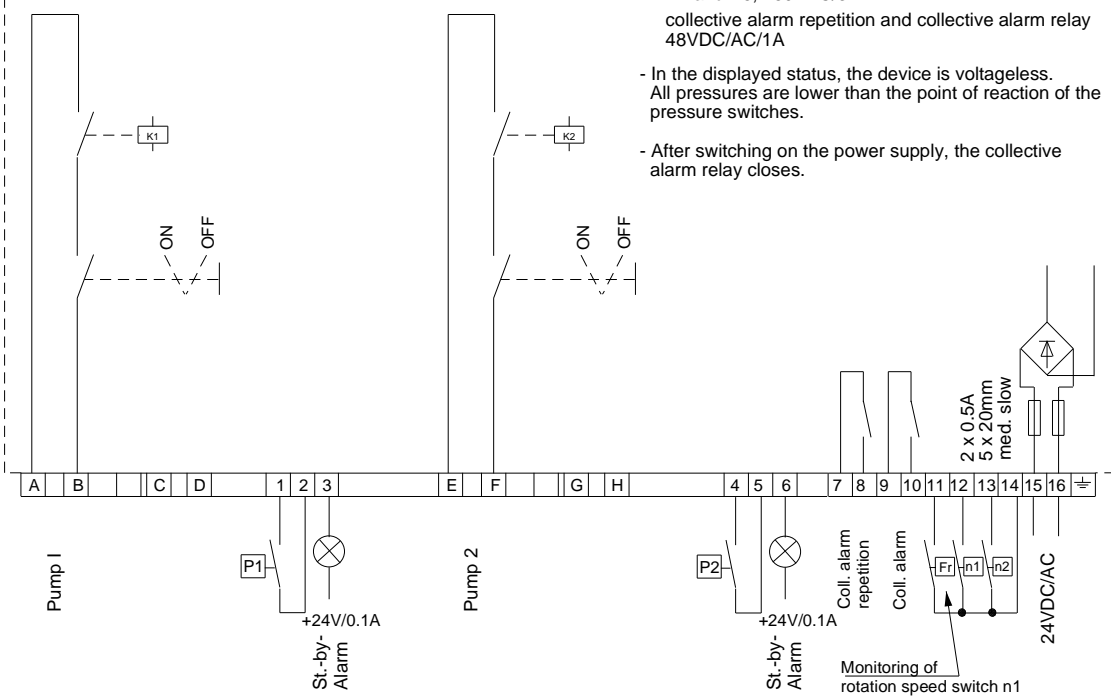

- Permissible load of relay contacts
K1 and K6, 250VAC/3A
collective alarm repetition and collective alarm relay
48VDC/AC/1A
- In the displayed status, the device is voltageless.
All pressures are lower than the point of reaction of the pressure switches.
- After switching on the power supply, the collective alarm relay closes.

The EEPROM (Type 28C64) is located on the upper card of the plug-in unit. If it has to be reprogrammed, it has to be torn out after loosening of the screw in the front panel.

Upper half of device	EEPROM address	Content (sec)	EEPROM address	Content ⁽¹⁾ (NC/NO)
t1	0700		----	----
t2	0701		----	----
Press. switch	----	----	0720	
Rot.sp.switch	----	----	0721	
Switch Fr	----	----	0724	

- 1) Pressure or rotation speed at closed contact
Pressure or rotation speed at open contact

- Content of address = 00
- Content of address = 01

Monitoring of rotation speed switch for the upper half of the device (n1) by closed switch Fr and content of address 0725 = 01

- Content of address = 00

Überwachung des Drehzahl Schalters für die obere Gerätehälfte (n1) durch geöffneten Schalter Fr und Inhalt der Adresse 0725 = 01

- Content of address = 01

Switch Fr. available?	Address	Content
If yes, content 01, if not, content 00	0725	

- t1) Time between pressure drop and starting of the st.-by-pump at high rotation speed (alarm, 0-99s).
t2) Switching-off of the st.-by-pump at running engine after "rotation speed switch off" and "pressure normal" (0-99s).

Lower half of device	EEPROM address	Content (sec)	EEPROM address	Content ⁽¹⁾ (NC/NO)
t1	0710		----	----
t2	0711		----	----
Press. switch	----	----	0722	
Rot.sp.switch	----	----	0723	

TECHNICAL DATA

- Power supply : 24VDC/AC
- Power cons. of the electronics : ca. 0.3A
- Degree of protection : - IP 20 (with front-cap IP 54)
- Rear : - IP 00
- Installation depth : 216mm
- Panel cutout : 138mm x 67mm
- Weight : ca. 1kg

Marking of the pump circuit

Marking of the pump circuit

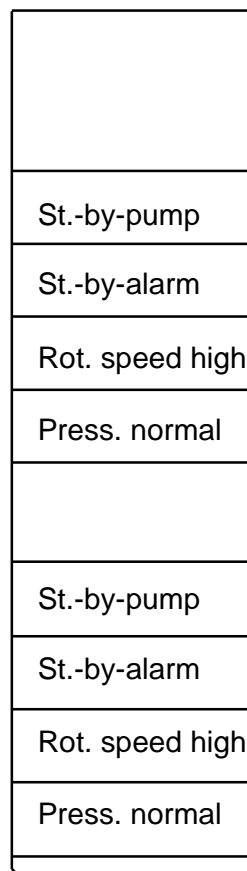

Text field for lettering, cutting out and insertion into the front panel from above.

4. AHD 408AE, as AHD 408 A, but with addressing of a prelubrication pump and switching-off of unimportant consumers

Upper part of device

St.-by-pump control for one electric prelubrication pump and one st.-by-pump each. The main pump is attached to the engine and not influenced by the control.

Lower part of device

As AHD 408A, but without transistor output for remote display st.-by-alarm.

4.1 Function

The following description of function only refers to the upper part of the device.

The following states have to be distinguished:

- At switched-off st.-by-pump-control the relay for addressing of the st.-by-pump has dropped (contact open). The transistors for addressing of the prelubrication pump and for „switching off unimportant consumers“ are blocked. Pressure and speed sensors do not have any influence.
- At switched-on st.-by-pump-control and stopped engine or at an engine running at low speed, the prelubrication pump is switched on. This state is normal, so there won't be a st.-by-alarm. If the speed rises up to the switching-point of the speed sensor device, the prelubrication pump stops independently of the pressure.
- Within a programmable range of time t_2 , the pressure has to be developed. If that is not accomplished, there will be a st.-by-alarm after running out of time t_1 . This has the following effects:
 - The output „switch off unimportant consumers“ is activated. App. 1s after that, the st.-by-pump is switched on. In case of falling below the switching point of the speed sensor (manual or automatic stop), the st.-by-pump is switched off, and the prelubrication pump is switched on.
 - red LED ST.-BY.-ALARM lights up at the front panel
 - transistor output with same definition for remote indicator switches through
 - collective alarm relay output opens
 - collective alarm repetition output closes for app. 3s and then opens again

AHD 408AE

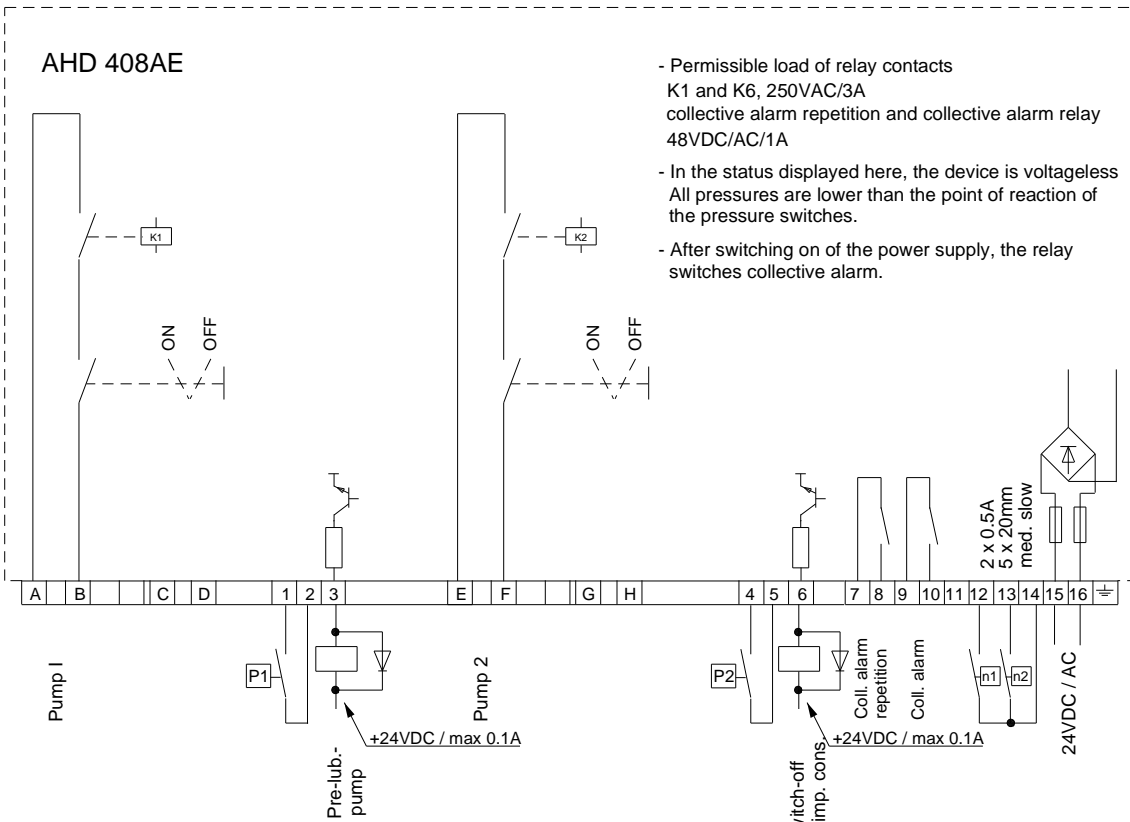

- Permissible load of relay contacts
K1 and K6, 250VAC/3A
collective alarm repetition and collective alarm relay
48VDC/AC/1A
- In the status displayed here, the device is voltageless
All pressures are lower than the point of reaction of
the pressure switches.
- After switching on of the power supply, the relay
switches collective alarm.

The EEPROM (Type 27C64) is located on the upper card of the plug-in unit. If it has to be reprogrammed, the plug-in unit has to be torn out after loosening the screw in the front panel.

Upper part of device	EEPROM address	Content (sec)	EEPROM address	Content ⁽¹⁾ (NC/NO)
t1	0700		----	----
t2	0708		----	----
Press. switch	----	----	0720	
Speed switch	----	----	0721	

- 1) Pressure and/or speed at closed contact → content of the address = 00
 Pressure and/or speed at opened contact → content of the address = 01
- t1) Time between pressure drop and starting of the st.-by-pump at high speed (occurring alarm, 0-99s).
- t2) After reaching high speed, pressure must have developed within this time. Otherwise, there will be a st.-by alarm after elapsing of time t1 (0-99s).

Lower part of device	EEPROM address	Content (sec)	EEPROM address	Content ⁽¹⁾ (NC/NO)
t1	0710		----	----
t2	0711		----	----
Press. switch	----	----	0722	
Speed switch	----	----	0723	

- 1) Pressure and/or speed at closed contact → content of the address = 00
 Pressure and/or speed at opened contact → content of the address = 01
- t1) Time between pressure drop and starting of the st.-by-pump at high speed (occurring alarm, 0-99s).
- t2) Switching off of the st.-by-pump at running engine after speed switch off and pressure normal (0-99s).

TECHNICAL DATA

- Power supply : 24VDC/AC
- Consumption of the electronics : app 0.3A
- Degree of protection : - IP 20 (with front-cap IP 54)
- Rear : - IP 00
- Installation depth : 216mm
- Panel cut-out : 138mm x 67mm
- Weight : app. 1kg

Marking of the pump circuit

Marking of the pump circuit

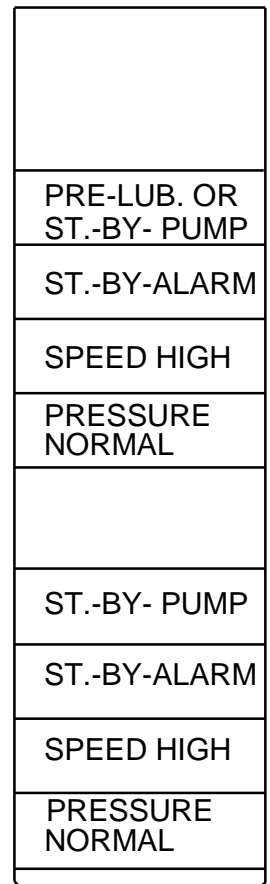

Text field for lettering, cutting out and insertion from above into the front panel.

5. AHD 408E-K, combined st.-by-pump- and compressor control

5.1 Function

AHD 408E-K contains a st.-by-pump control for electric main- and st.-by-pumps and a st.-by-compressor control. Operation is identical with that of AHD 408E.

The compressor control works as follows:

At the front panel of the device, one selector switch „MAIN COMPR“ and one switch „ON“ are installed. With the last mentioned, the control is commissioned. The selector switch determines, which compressor shall operate as main compressor and which as st.-by-compressor.

Control is mainly determined by the status of three pushbuttons. They are defined as follows:

P1	lowest pressure
P2	medium pressure
P3	high pressure

After switching the control device on, the system checks the condition of the keys. If the pressure is lower than P1 (e. g. putting into operation), the main compressor starts immediately. If the air consumption is very high, so that P3 is not reached, the st.-by-compressor switches, too. If P3 is reached, both compressors switch off. If, after elapsing of time t_3 , both compressors do not succeed to develop the pressure P3, a st.-by-report occurs, which is, in detail, as follows:

- red LED ST.-BY.-ALARM lights up at the front panel
- transistor output with same definition for remote indicator switches through
- collective alarm relay output opens
- collective alarm repetition output closes for app. 3s and then opens again

The st.-by report can be reset by brief switching-off of the „ON“-switch, which also has a RESET-FUNCTION.

During normal operation, the main compressor switches on after falling below P2 and after elapsing of time t_1 and is switched off after reaching P3. In case of a blackout, all compressors stop. After restoration of power and elapsing of time t_1 , the previous state of operation is restored.

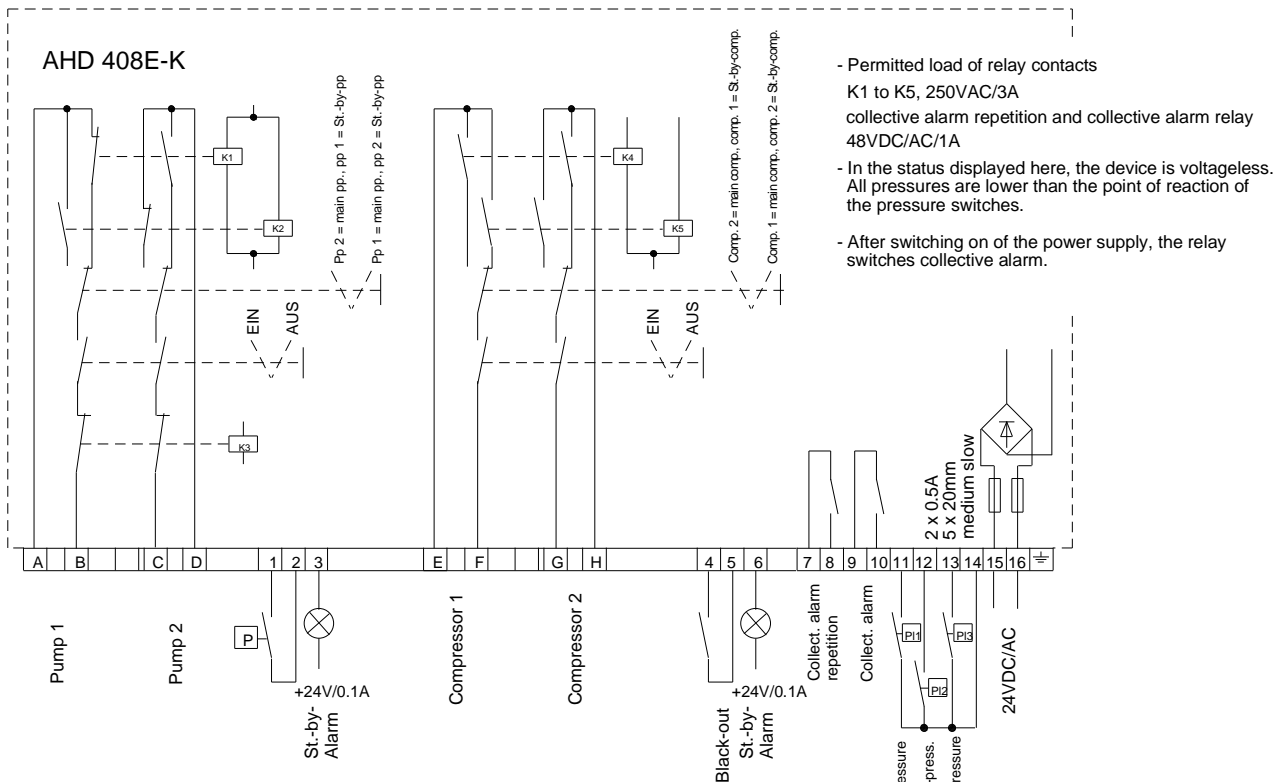

- Permitted load of relay contacts
K1 to K5, 250VAC/3A
collective alarm repetition and collective alarm relay
48VDC/AC/1A
- In the status displayed here, the device is voltageless.
All pressures are lower than the point of reaction of
the pressure switches.
- After switching on of the power supply, the relay
switches collective alarm.

The EEprom (Type 28C64) is located on the upper card of the plug-in unit. If it has to be reprogrammed, the plug-in unit has to be torn out after loosening the screw in the front panel.

Upper part of device	EEprom address	Content (min)	EEprom address	Content (sec)
t1	0700		0701	
t2	----	----	0702	
t3	----	----	0703	

- 1) Pressure at closed contact — content of the address = 0
 Pressure at open contact — content of the address = 01
- t1) Permitted time from switching on the st.-by-pump until reaching operating pressure during the start program. This time is the same as the time that is available for the operating pump after a black-out to redevelop the pressure (0-99min and 59s).
- t2) Time between pressure drop and stopping of the main pump (0-99s)
- t3) Time until restarting of the operating pump after a black-out (0-99s).

Compressor-control	EEprom address	Content (min)	EEprom address	Content (sec)	EEprom address	Content (1) (NC/NO)
t1	----	----	0710		----	----
t2	----	----	0711		----	----
t3	0712		0713		----	----
Press. switch 1	----	----	----	----	0717	
Press. switch 2	----	----	----	----	0718	
Press. switch 3	----	----	----	----	0719	

NO = Pressure > Switch pressure when contact open; content of the address = 00
 NC = Pressure > Switch pressure when contact closed; content of the address = 01

- t1 = Time from p < p2 until starting of main compressor (0-99s).
 It is equal to the time that has to pass after a black-out, before the main compressor is switched on again.
- t2 = Time from p < p1 until starting of st.-by-compressor (0-99s).
- t3 = Permissible time of operation of the st.-by- compressor until a St.-by-alarm is released, as far as p is < p2 (0-99min and 59s)

- TECHNICAL DATA**
- Power supply : 24VDC/AC
 - Consumption of the electronics : app. 0.3A
 - Degree of protection : - IP 20 (with front-cap IP 54)
: - IP 00
 - Installation depth : 216mm
 - Panel cutout : 138mm x 67mm
 - Weight : app. 1kg

Marking of the pump circuit

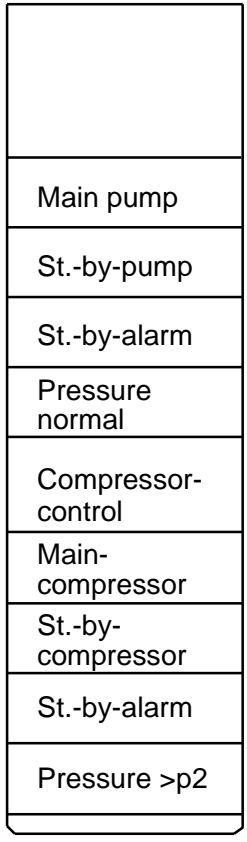

Text field for labelling, cutting out and inserting from above into the front panel.

216

200

15

72

144

- 1
- 2
- 3
- 4
- 5
- 6
- 7
- 8
- 9
- 10
- 11
- 12
- 13
- 14
- 15
- 16
- 17
- 18
- 19
- 20
- 21
- 22
- 23
- 24

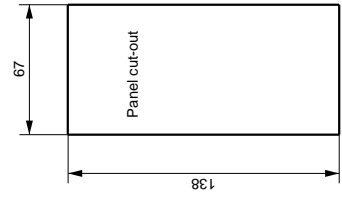
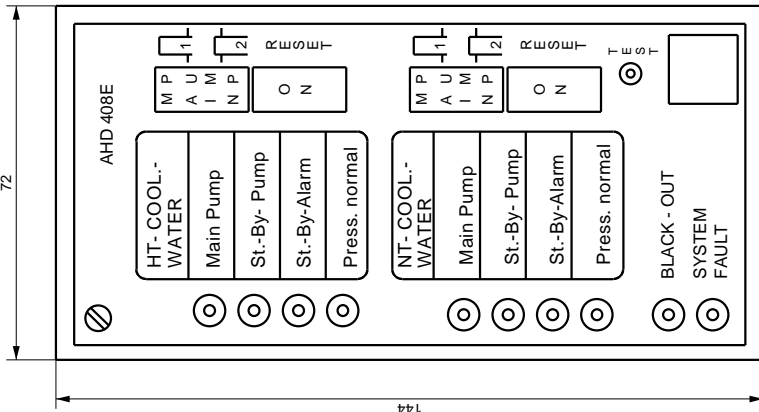
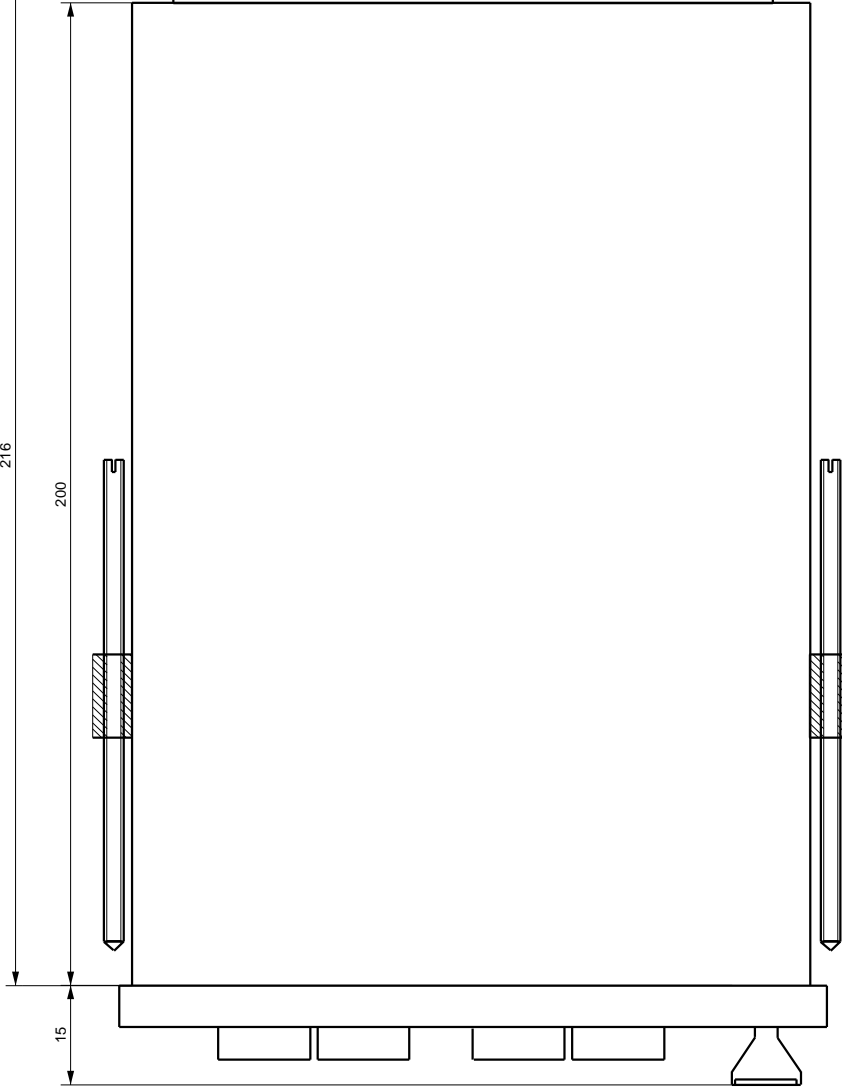

Drawing: 408ZK-E.mcd

DIMENSIONAL DRAWING FOR
ALL PUMP- AND COMPRESSOR-
CONTROLS OF THE
AHD 408 SERIES

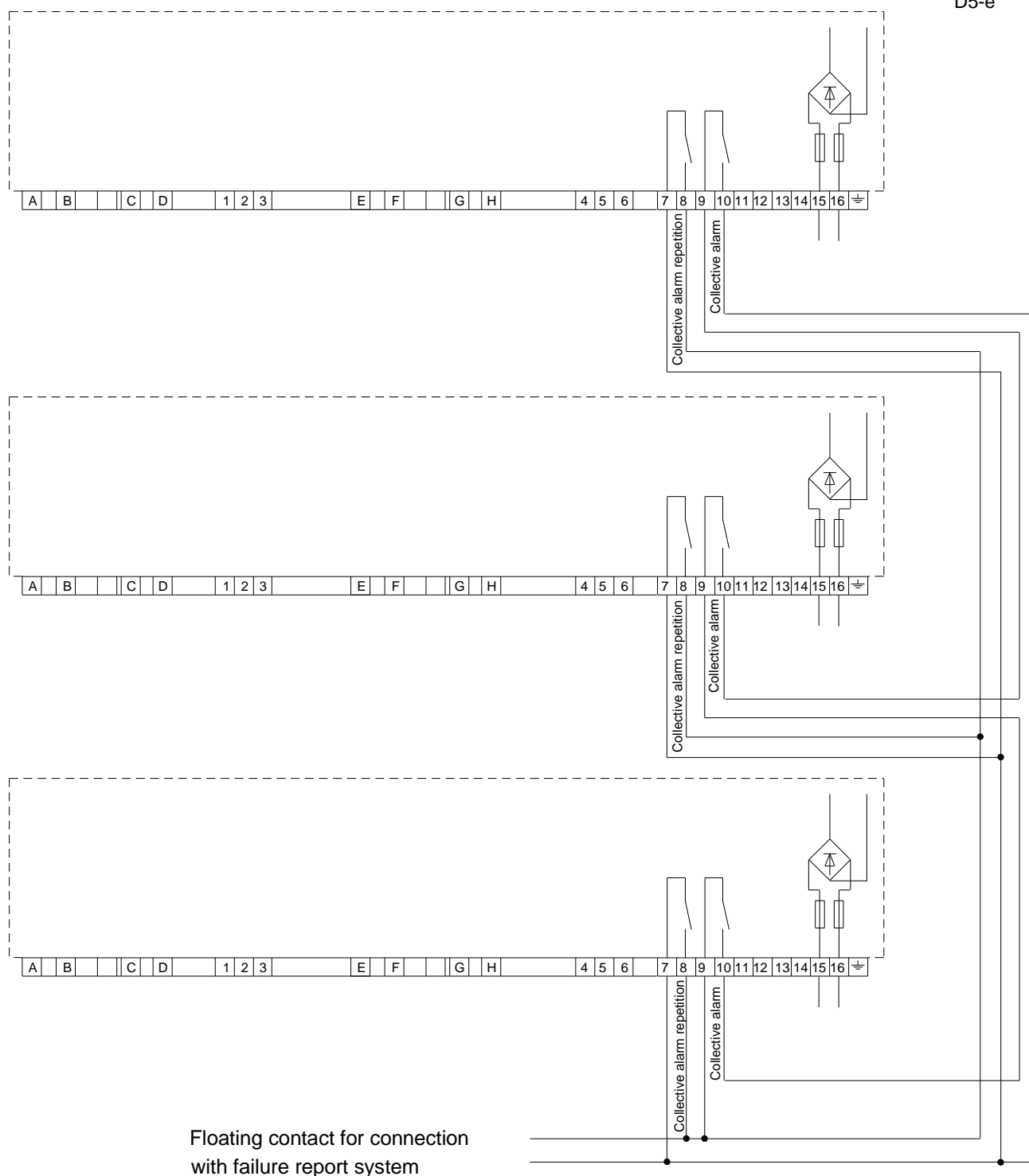

Floating contact for connection
with failure report system

Collective report for the failure report system

It is possible to lead the collective reports of an arbitrary amount of devices of the AHD 408 series onto a single measuring point of the failure report system. In order to do this, the collective report outputs are switched in line and all collective alarm repetition outputs are switched parallel. Both signals are then switched parallel again and led to the failure report system as floating contact.

The collective alarm contacts open in the event of a st.-by-alarm. The collective alarm repetition contacts close for approximately 3s. Thus, the measuring point in the failure report system is shortly reset and then activated again.

Thus it is ensured that every alarm leads to repeated addressing of the failure report system, even if it had already been activated by the report of a different device.

In this example, three devices are connected this way.

AHD 408A

AHD 408E

AHD 408E-K

Marking of the
pump circuit



St.-by-pump
St.-by-alarm
Speed high
Press. normal
St.-by-pump
St.-by-alarm
Speed high
Press. normal

Main pump
St.-by-pump
St.-by-alarm
Press. normal
Main pump
St.-by-pump
St.-by-alarm
Press. normal

Main pump
St.-by-pump
St.-by-alarm
Press. normal
Compressor control
Main compressor
St.-by-compressor
St.-by-alarm
Press. >p2

Marking of the
pump circuit



Text fields for marking,
cutting out and insertion
from above into the front
panel.