

AHD 882

Central Unit for Alarm, Monitoring and Control Systems

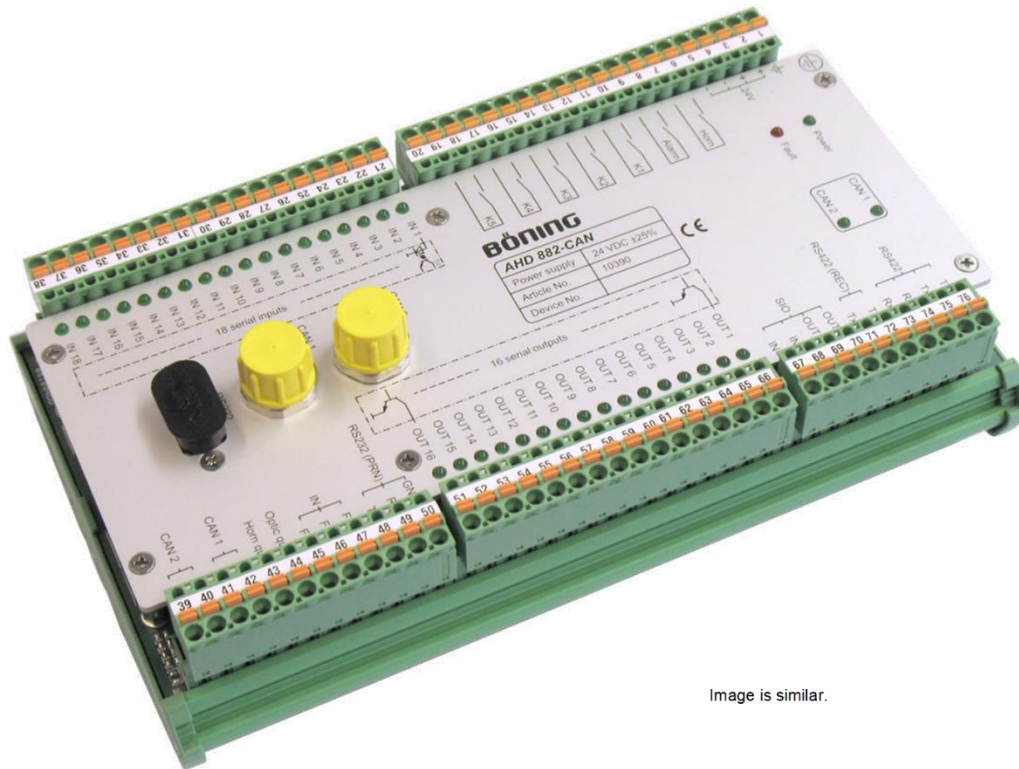

Image is similar.

General

The central unit AHD 882 is a microcontroller-operated device, designed for the acquisition, processing and distribution of binary status data and analog limit values (alarms, events, messages etc.). The data (e.g. data from sensors of a ship alarm, monitoring and control system) are serially transmitted from decentralized connected external data acquisition stations and processing devices and processed by an integrated alarm, display and control management.

The electronics of the unit is fitted in a profile module, prepared for installation on standard profile rails in consoles, control panels or control cabinets.

The cable connection is performed by two terminal strips, consisting of pluggable terminal modules with cage-clamp terminals, as well as plug connectors for RS232-interface (9-pole D-Sub plug connector) and CAN bus connection (2 x Lumberg DeviceNet plug connector).

The central unit AHD 882 provides 18 input channels for serial transmission of data, externally acquired i.e. by the following devices:

- Binary Data Station AHD-PS 15, 15 binary inputs
- Binary Data Station AHD-PS 30, 30 binary inputs
- Binary Data Station AHD-PS 47, 47 binary inputs
- Diesel-Start-Stop-Automat AHD 414
- Safety System AHD 414 A
- Alarm and Indication system EDA 47, 47 binary inputs

At two CAN bus interfaces, binary status data of measuring points, which are monitored by data acquisition stations connected to CAN Bus network can be filtered and recorded from the CAN data protocol, e.g.:

- Data Station AHD-SAS 15, 15 analog/ binary inputs
- Navigation Light Monitoring System AHD-DPS02

All received data are processed according to a predefined project specific configuration and distributed as processed output data to the 16 output channels of the unit, where the following indication and control devices can be connected:

- Alarm and Indication System EDA 47
- Group Alarm and Indication System EDA 47
- Cabin Duty Alarm/Engineer Call Panel AHD 406-2
- Relay Station AHD-R101

The data may also transmitted via the CAN bus to external stations connected to the network, e.g. color displays AHD 652, AHD 880 TC and panel PCs.

The central unit AHD 882 may process and distribute binary status data and analog limit values of up to 846 measuring points.

An internal memory is used to store the last 10.000 recorded messages with date/time information. AHD 882 unit distinguishes between status messages and alarm messages as well as between switch-on/switch-off events.

Either an alarm and event log printer or an alarm and event log computer can be connected to the integrated RS232 interface to allow printing or listing of recorded messages and storage of these data in log files.

Further additional control inputs, acknowledgement inputs and alarm and group relay outputs extend the scope of functionality of AHD 882 and allow various fields of application.

The system (AHD 882 plus connected external devices) is configured with a software configuration tool, which is part of the scope of delivery. With this tool, the whole project-specific measuring point list can be adjusted with the configuration of all required parameters like status or alarm message, delay times, alarm on open or closed contact etc. The tool allows the comfortable configuration in clearly arranged data tables.

Technical Information Central Unit AHD 882:

Technical Data

• Mechanical Data

Dimension W x H x D	216 x 125 x 71 mm
Weight	Ca. 0.6 kg

• Environmental Data

Operating Temperature	-30°C ... +70°C
Storage Temperature	-50°C ... +85°C
Degree of Protection	IP 20
Required Minimum Distance to Compass	Steering magnetic compass: 0.65 m Standard magnetic compass: 0.75 m

• Electrical Data

Power Supply	24 V DC (+30% - 25%)
Current Consumption, max.	125 mA

• Interfaces

Serial Inputs	18 x Serial In (Optocoupler, switched to minus)
Serial Outputs	16 x Serial Out (wire-breakage monitored, transmission cycle 250 ms)
Bus-Interfaces	2 x CAN bus (Option. redundant), each applied with DeviceNet-plug connector and terminal list connection
Serial Interfaces	1 x RS232 for alarm log printer, PC for configuration or alarm logging (9-pole Sub-D connector and terminal list connection or alternatively 1 x RS422 Output to VDR (terminal list connection) 1 x RS422/485 Output (optional, terminal list connection)
Relay Outputs	5 x Group relays (K1 – K5, NO or NC output configurable) 1 x Alarm relay (configurable as common alarm relay. (NC), control relay for light calling columns or group relay) 1 x Horn relay(NO)
Binary Inputs	1 x Horn Quit (acknowledgement of audible alarm) 1 x Optic Quit (acknowledgement of visual alarm) 3 x Function Input (F1 – F3, optional)

• Installation

Profile module for direct installation on profile rails TS 32 or TS 35 in consoles, panels or cabinets

• Approvals

Classification Societies	DNV, CRS, LR, RS
--------------------------	------------------

• Item number

10390

Technical Information
Central Unit AHD 882:

Dimension:

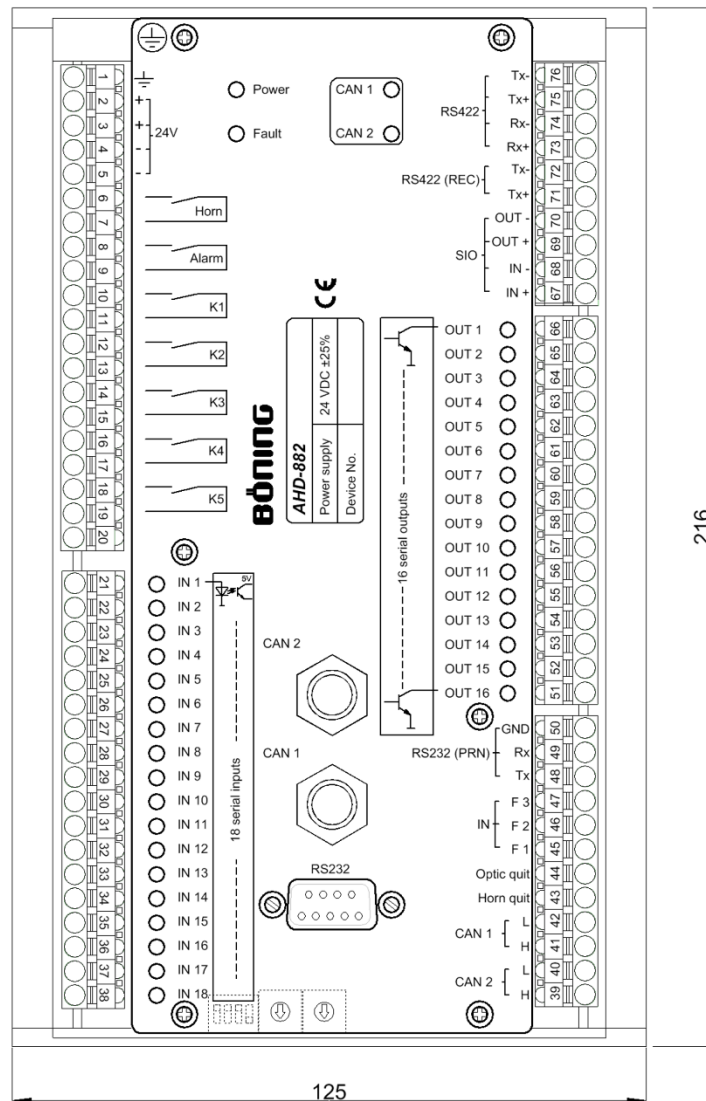
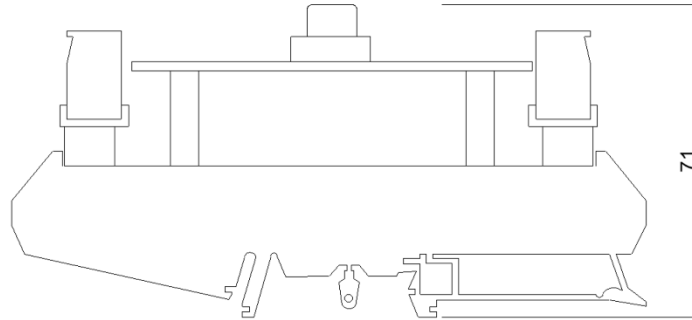
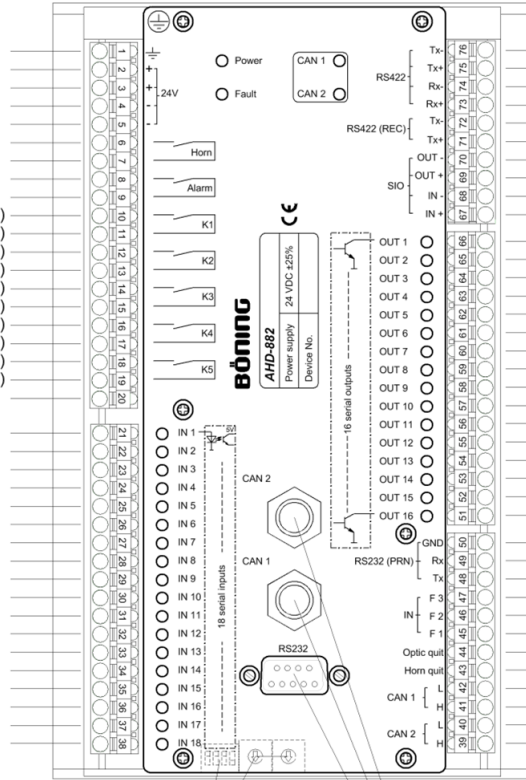

Image is similar.

Technical Information Central Unit AHD 882:

Connection:

- 1: Earth
- 2: 24 V DC (18 ... 32 V DC): +
- 3: 24 V DC (18 ... 32 V DC): +
- 4: 24 V DC (18 ... 32 V DC): -
- 5: 24 V DC (18 ... 32 V DC): -
- 6: Horn (Relay output , pot.free)
- 7: Horn (Relay output , pot.free)
- 8: Alarm (Relay output , pot.free)
- 9: Alarm (Relay output , pot.free)
- 10: Group K1 (Relay output , pot.free)
- 11: Group K1 (Relay output , pot.free)
- 12: Group K2 (Relay output , pot.free)
- 13: Group K2 (Relay output , pot.free)
- 14: Group K3 (Relay output , pot.free)
- 15: Group K3 (Relay output , pot.free)
- 16: Group K4 (Relay output , pot.free)
- 17: Group K4 (Relay output , pot.free)
- 18: Group K5 (Relay output , pot.free)
- 19: Group K5 (Relay output , pot.free)
- 20: 24 V DC : +, Supply serial input
- 21: Serial Input IN 1 (Optocoupler)
- 22: Serial Input IN 2 (Optocoupler)
- 23: Serial Input IN 3 (Optocoupler)
- 24: Serial Input IN 4 (Optocoupler)
- 25: Serial Input IN 5 (Optocoupler)
- 26: Serial Input IN 6 (Optocoupler)
- 27: Serial Input IN 7 (Optocoupler)
- 28: Serial Input IN 8 (Optocoupler)
- 29: Serial Input IN 9 (Optocoupler)
- 30: Serial Input IN 10 (Optocoupler)
- 31: Serial Input IN 11 (Optocoupler)
- 32: Serial Input IN 12 (Optocoupler)
- 33: Serial Input IN 13 (Optocoupler)
- 34: Serial Input IN 14 (Optocoupler)
- 35: Serial Input IN 15 (Optocoupler)
- 36: Serial Input IN 16 (Optocoupler)
- 37: Serial Input IN 17 (Optocoupler)
- 38: Serial Input IN 18 (Optocoupler)



- 76: Interface RS422: Tx -
- 75: Interface RS422: Tx +
- 74: Interface RS422: Rx -
- 73: Interface RS422: Rx +
- 72: Interface RS422 (VDR): Tx -
- 71: Interface RS422 (VDR): Tx +
- 70: Serial Interface (Optocoupler): Out -
- 69: Serial Interface (Optocoupler): Out +
- 68: Serial Interface (Optocoupler): In -
- 67: Serial Interface (Optocoupler): In +
- 66: Serial Output OUT 1
- 65: Serial Output OUT 2
- 64: Serial Output OUT 3
- 63: Serial Output OUT 4
- 62: Serial Output OUT 5
- 61: Serial Output OUT 6
- 60: Serial Output OUT 7
- 59: Serial Output OUT 8
- 58: Serial Output OUT 9
- 57: Serial Output OUT 10
- 56: Serial Output OUT 11
- 55: Serial Output OUT 12
- 54: Serial Output OUT 13
- 53: Serial Output OUT 14
- 52: Serial Output OUT 15
- 51: Serial Output OUT 16
- 50: Interface RS232 (Printer): GND
- 49: Interface RS232 (Printer): Rx
- 48: Interface RS232 (Printer): Tx
- 47: Control Input F 3
- 46: Control Input F 2
- 45: Control Input F 1
- 44: Input: Optic alarm acknowledge
- 43: Input: Acoustic alarm acknowledge
- 42: CAN-Bus Port 1: L
- 41: CAN-Bus Port 1: H
- 40: CAN-Bus Port 2: L
- 39: CAN-Bus Port 2: H

4-pole DIP-switch (see Detail 1)
2 x BCD-switch for future functions

CAN-Bus Port 2: Lumberg Plug Connector, male
CAN-Bus Port 1: Lumberg Plug Connector, male
Interface RS232 (Printer): D-Sub, 9-pole, female

Image is similar.

Detail 1:
Configuration of RS232 interface by
4-pole DIP-switch



Switch 1 to 4 = OFF: serial communication
via RS232 to PC/Laptop with configuration tool



Switch 1 = ON: serial printing via RS232 printer or
alarm log via RS232 on display of service computer.



Switch 4 = ON: flashing new firmware via RS232